

# SERVOTOUGH 1800

## ACCURATE, ANALOG AND HIGHLY SPECIFIC OXYGEN ANALYZER FOR SAFE AREAS AND ENRICHED OXYGEN SAMPLES



### SERVOTOUGH 1800

The SERVOTOUGH 1800 simplifies safe area O<sub>2</sub> monitoring by delivering a powerful value-added package of features built around highly accurate and reliable oxygen monitoring capabilities, utilizing the patented Servomex Paramagnetic oxygen transducer. Compared to other technologies, the Paramagnetic transducer is non-depleting and requires minimal calibration - ensuring low cost of ownership.

The enclosure has an ingress protection of IP66/NEMA 4 allowing indoor or outdoor installation of the analyzer.

The analyzer has clear displays, indicators and enclosed controls. The ruggedness and reliability of the analyzer make it suitable for critical applications. Isolated 4-20mA and non-isolated 0-1V dc analog output signals allow the analyzer to be connected to distributed control systems (DCS), recorders and annunciator panels.

The analyzer complies with the latest European and EMC Directives

### FLEXIBLE

- Special high flow rate cell option
- Special versions for solvent bearing samples
- Automatic flow control device and back pressure regulator options available

### EASY TO USE

- Range of alarm outputs to aid integration with other systems
- Easy to set up and operate
- Clear displays, indicators and enclosed controls
- Internal/external use (IP66/NEMA 4X rated)

### LOW COST OF OWNERSHIP

- Long calibration intervals and cell life
- Reliable and rugged analog based electronics
- Proven longlife Servomex paramagnetic technology

### UNRIVALLED PERFORMANCE

- Designed for safe area, oxygen enriched analysis
- Uses industry leading patented Paramagnetic technology for stable, non-depleting measurement
- Manufactured by Servomex - over 60 years' experience innovating and pioneering gas analysis, and thousands of units used in the field every year

### BENCHMARK COMPLIANCE

- CSA (Canada) Safety Requirements for Electrical Equipment for Measurements, Control and Laboratory Use: Part 1: General Requirements
- IEC 61010-1
- Overvoltage Category II, Pollution Degree 2
- EU EMC Directive
- EU Low Voltage Directive

Learn more about the SERVOTOUGH 1800  
VISIT [SERVOMEX.COM](http://SERVOMEX.COM)



[SERVOMEX.COM](http://SERVOMEX.COM)

## RELIABLE, HIGH ACCURACY SAFE AREA MONITORING

For applications such as ambient air monitoring, inerting or gas cylinder storage, you need an adaptable, high performance O<sub>2</sub> analytical solution you can truly rely on.

Your job demands maximized efficiency, so your gas analysis needs to be highly stable and reliable. It has to be capable of easily integrating into your existing safety infrastructure and flexible in terms of settings and options. No matter what processes you are operating, the need for affordable cost of ownership is a must. We don't believe you should have to compromise.

## NON-DEPLETING SENSOR PERFORMANCE

The 1800 utilizes Servomex's world-leading Paramagnetic O<sub>2</sub> sensing technology, which provides highly reliable, accurate and stable percentage measurements of O<sub>2</sub>. Unlike electrochemical technologies, the non-depleting technology requires minimal calibration and never needs replacing. The result is a long life with low maintenance costs.

## AFFORDABLE, VALUE-ADDED FEATURES

The 1800 features have been specifically designed to ease everyday operation and maximize performance. Optional high flow cell, automatic flow control device (AFCD), back pressure regulator (BPR) and sample flow switch allow a fit to existing sample systems and aid overall performance, whilst also offering preventative maintenance.

## ALTERNATIVE PRODUCTS

The SERVOTOUGH and DF range offer alternative options for oxygen analysis, including:

### Oxy 1900



The award-winning Oxy sets the standard for O<sub>2</sub> gas analysis, delivering an intelligent, feature-rich solution designed to meet the monitoring needs of even the most challenging applications.

### DF-300



When trace and ultra-trace O<sub>2</sub> analysis is needed, the DF-300 series provides a feature-rich solution in an intelligent digital format. This device's coulometric E-sensor provides no drift or false low readings, helping to extend calibration periods.

## KEY APPLICATIONS

- Ambient air monitoring
- Waste water treatment
- Food storage
- Marine inerting applications
- Clean room/glove boxes
- Inert blanketing
- Gas cylinder storage



# PRODUCT DATA: 1800

OPTIONS	DESCRIPTION	SPECIFICATION
Analog outputs	2 x Standard	1 x isolated 4-20mA 1 x 0-1V dc non-isolated. Ranges selectable from 0-2.5, 5, 10, 25 and 100% O <sub>2</sub>
Alarms: Concentration Sample flow fail	2 x volt free changeover relays 1 x volt free changeover relay	Rated 250V ac/3A or 28V dc (non inductive) maximum and 5V/10mA ac/dc minimum
Pipe work	Materials available dependent on sample stream	Viton for standard gases. Stainless steel for solvent bearing samples
AFCD	Automatic flow control device	Allows inlet pressures from 1-5psig (7-35kPag)
Flow Alarm	Added sampling performance and preventative maintenance	
Back pressure regulator	Added measurement performance	Regulates analyzer back pressure for improved measurement stability
Output range	Analog output parameters	user selectable over the measurement range
Power supply	Options for use	100 to 240V ac $\pm$ 10%, 50/60Hz - 50VA max
Solvent samples	Specific model variant	Perfluoroelastomer O-rings for robust sample handling

## ACCESSORIES

**ACCESSORIES AVAILABLE FOR SPECIFIC APPLICATIONS  
- CONTACT YOUR LOCAL SERVOMEX BUSINESS CENTER**

MEASUREMENT PERFORMANCE	
Gas	O <sub>2</sub>
Technology	Paramagnetic
Range	0-100% O <sub>2</sub>
Accuracy (intrinsic error)	<0.2% of reading or 0.05% O <sub>2</sub> *
Repeatability	<0.1% of reading or 0.05% O <sub>2</sub> *
Zero drift/week	<0.05% O <sub>2</sub>
T <sub>90</sub> response time	4 to 8 seconds **
Operating Temperature	-10°C to 50°C (14°F to 122°F)

\* Whichever is greater

\*\* Dependent on sampling options



# PRODUCT DATA: 1800

## SAMPLE FOR MEASUREMENTS

<b>Sample gas</b>	The sample gas must be clean, non-corrosive and free from oil and condensates
<b>Flow control</b>	Standard: 50 – 250ml/min (200ml/min recommended). Optional high flow internal bypass: 50-70l/h (60l/h recommended)
<b>Sample inlet connection</b>	¼" NPT female, 6mm tube
<b>Sample wetted material (basic analyzer)</b>	Borosilicate Glass, Fluorocarbon Rubber, Nickel (electroless), Platinum, Platinum/Iridium alloy, Polypropylene, 303 Stainless Steel, 316 Stainless Steel, Viton (325 Cell)
<b>Sample vent pressure</b>	11.5 to 18.0psia (80.5 to 126kPaa)
<b>Inlet pressure (basic analyzer)</b>	0.04psig (0.3 kPaa) minimum (adjust pressure and sample flow externally to provide sample flow rate)

## DEVICE SPECIFICATION

### Size:

- 448mm (17.6") Width x 235mm (9.2") High x 229mm (9") Deep

### Weight:

- 26 kg/57 lbs

### Certifications:

- CSA (Canada)  
Safety Requirements for Electrical Equipment for Measurements, Control and Laboratory Use: Part 1: General Requirements
- IEC 61010-1
- Overvoltage Category II, Pollution Degree 2
- EU EMC Directive
- EU Low Voltage Directive

*These analyzers are not intended for any form of use on humans and are not medical devices as described in the Medical Devices Directive 93/42EEC.*

## DEVICE SCHEMATIC

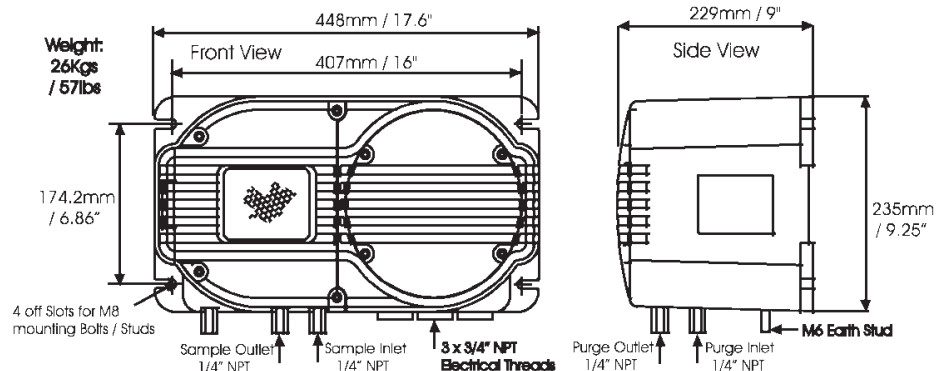

**Please note:** This document was updated in February 2015. While every effort has been made to ensure accuracy, no responsibility can be accepted for errors or omissions. Data may change, as well as legislation, and you are strongly advised to obtain copies of the most recently issued regulations, standards and guidelines. This document is not intended to form the basis of a contract.

PB1800 Rev.0 Date: 06/16

AMERICAS BUSINESS CENTER  
Tel: +1 281 295 5800  
Email: americas\_sales@servomex.com

ASIA PACIFIC BUSINESS CENTRE  
Tel: +86 (0)21 6489 7570  
Email: asia\_sales@servomex.com

EUROPEAN BUSINESS CENTRE  
Tel: +31 (0) 79 330 1580  
Email: europe\_sales@servomex.com

INDIA BUSINESS CENTRE  
Tel: +91 22 3934 2700  
Email: MEI\_sales@servomex.com

MIDDLE EAST BUSINESS CENTRE  
Tel: +971 6552 8073  
Email: MEI\_sales@servomex.com

SERVOMEX.COM

Servomex has a policy of constant product improvement and reserves the right to change specifications without notice.  
© Servomex Group Limited. 2015. A Spectris company. All rights reserved.

**SERVOMEX**